

ADVANCED COMBUSTION SYSTEMS

ENGINEERING
MANUFACTURING
INSTALLATION
SERVICE

CONTROLLED AIR ANIMAL CREMATORIES

Advanced Combustion Systems' CA-Series Controlled Air **Batch Load** Animal Crematories are designed and manufactured with the latest industry technology, providing a rugged and durable incinerator. ACS CA-Series animal crematories are engineered for maximum performance and efficiency while maintaining high reliability with low maintenance, meeting the most stringent EPA emission requirements throughout the world.



FEATURES:

- Heavy-duty all welded construction
- High strength, durable monolithic castable refractory lining
- Fully automatic electrical controls
- Simple and reliable operation
- Full swing combustion chamber door for total access
- Modular design for easy installation
- Factory plumbed, wired, and tested prior to shipment
- Designed and manufactured in the USA
- 5 YEAR "Total Component Warranty"

ADVANCED COMBUSTION SYSTEMS

A Division of ACS Inc.

1999 ALPINE WAY, BELLINGHAM WA 98226
PHONE: (360) 676-6005 • FAX: (360) 647-9439
E-MAIL: info@acs-accs.com



1. PRIMARY COMBUSTION CHAMBER
2. SECONDARY COMBUSTION CHAMBER
3. PRIMARY BURNER(S)
4. PRIMARY BLOWER
5. SECONDARY BURNER(S)
6. SECONDARY BLOWER
7. PRIMARY LOAD DOOR
8. INCINERATOR STACK
9. CONTROL PANEL

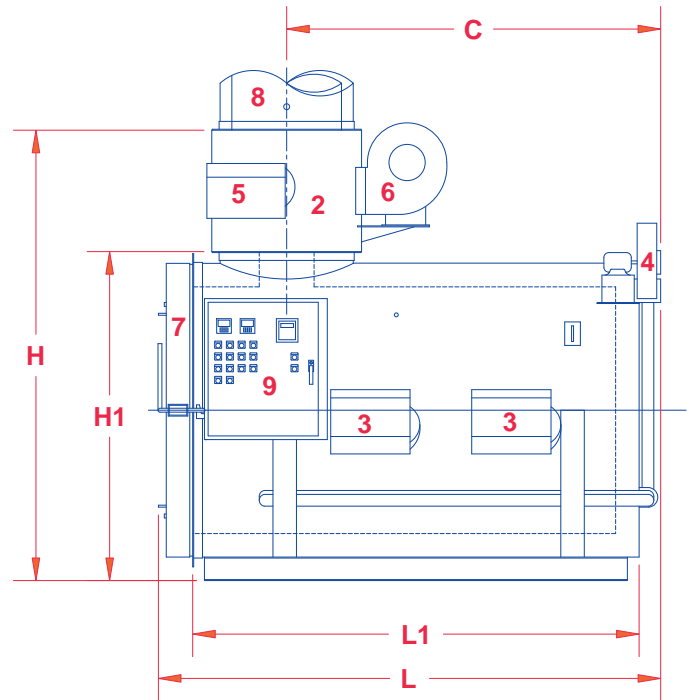
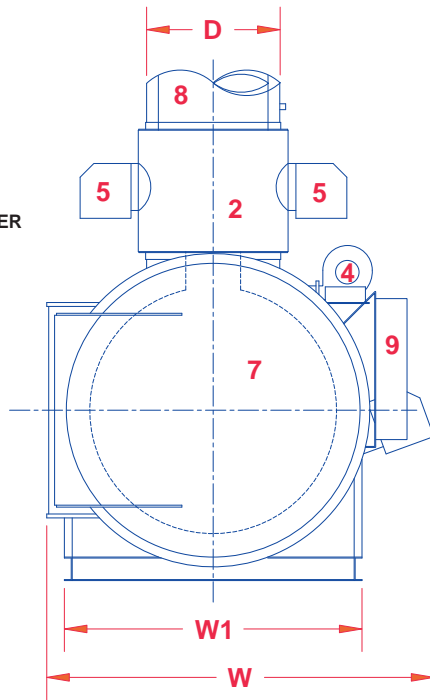

MODEL NUMBER	OVERALL DIMENSIONS ¹								MAX. CHARGE CU. FT.	BURN RATE (MAX.) LBS./HR. ²	APPROX. WEIGHT LBS. ³
	H	H1	W	W1	L	L1	C	D			
CA-50	5'-10"	3'-10"	5'-0"	3'-2"	5'-0"	4'-0"	3'-4"	1'-4"	14	25 - 65	2,800
CA-100	6'-4"	4'-4"	5'-8"	3'-10"	6'-2"	5'-0"	4'-3"	1'-6"	27	50 - 125	4,100
CA-150	7'-4"	5'-4"	6'-5"	4'-8"	7'-0"	5'-6"	4'-5"	1'-10"	41	75 - 190	6,200
CA-200	7'-7"	5'-4"	6'-5"	4'-8"	8'-8"	7'-6"	6'-4"	2'-0"	54	100 - 250	8,000
CA-300	8'-7"	6'-5"	7'-6"	5'-8"	8'-1"	6'-10"	5'-4"	2'-2"	81	150 - 375	14,000
CA-400	9'-0"	6'-5"	7'-6"	5'-8"	11'-6"	9'-0"	8'-0"	2'-6"	108	200 - 500	16,800
CA-500	9'-8"	7'-1"	8'-2"	6'-3"	10'-10"	9'-6"	8'-0"	2'-10"	135	250 - 625	19,700
CA-750	10'-7"	7'-1"	8'-2"	7'-0"	11'-6"	9'-6"	8'-0"	2'-10"	203	375 - 940	22,500
CA-1000	10'-7"	7'-9"	9'-0"	7'-0"	15'-6"	13'-6"	9'-6"	3'-6"	270	500 - 1,250	27,500
CA-1250	11'-2"	7'-9"	9'-0"	7'-0"	19'-6"	16'-6"	13'-6"	4'-0"	338	625 - 1,563	38,000
CA-1500	13'-1"	9'-1"	10'-3"	8'-4"	14'-7"	13'-6"	11'-0"	4'-0"	405	750 - 1,875	40,000

1. Dimensions can be modified to meet specific applications 2. Actual burning rate depends upon waste composition. 3. Weight will vary depending on the options ordered.

SERVICES:

- Installation and start-up services
- Large parts inventory for immediate shipment
- Service and maintenance contracts for all makes
- Rebuilds and modifications to existing incinerators

OPTIONS:

- Fully modulate air supply, temperature controls
- Fully integrated PLC controls
- Extra retention secondary chambers
- Auxiliary load doors
- Automatic ash removal

Advanced Combustion Systems' Engineering and Testing Facilities are available for complete design and component selection. ACS can custom design and manufacture incineration and control systems to meet any specific application.

ACS, Inc. is your sole source manufacturer for complete incineration systems including waste handling, heat recovery, emission controls and monitoring.



ACS INCORPORATED
 1999 ALPINE WAY BELLINGHAM, WA 98226
 PHONE: 360.676.6005 FAX: 360.647.9439
 TOLL FREE: 800.445.0243
 WWW.ACS-ACS.COM

