

ADVANCED COMBUSTION SYSTEMS

ENGINEERING
MANUFACTURING
INSTALLATION
SERVICE

POULTRY AND AGRICULTURE CREMATORIES

Advanced Combustion Systems' PAC-Series Poultry/Animal Crematories are designed and manufactured with the latest industry technology, providing a rugged and durable incinerator for harsh environments. ACS PAC-Series incinerators are engineered for maximum performance and efficiency while maintaining high reliability with low maintenance, meeting the most stringent EPA emission requirements throughout the world.

FEATURES:

- Heavy-duty all welded construction
- High strength, durable monolithic castable refractory lining
- Fully automatic electrical controls
- Simple and reliable operation
- Full swing chamber clean-out door for total access
- Top load door for easy loading with tractor, bobcat, forklift or other equipment
- Modular design for easy installation
- Factory plumbed, wired, and tested prior to shipment
- Designed and manufactured in the USA
- 5 YEAR "Total Component Warranty"

OPTIONS:

- Fully modulated air supply, temperature controlled
- Fully integrated PLC controls
- Extra retention secondary chambers
- Auxiliary load doors
- Automatic waste loading systems
- Automatic ash removal systems



ADVANCED COMBUSTION SYSTEMS

A Division of ACS Inc.

1999 ALPINE WAY, BELLINGHAM WA 98226
PHONE: (360) 676-6005 • FAX: (360) 647-9439
E-MAIL: info@acs-accs.com



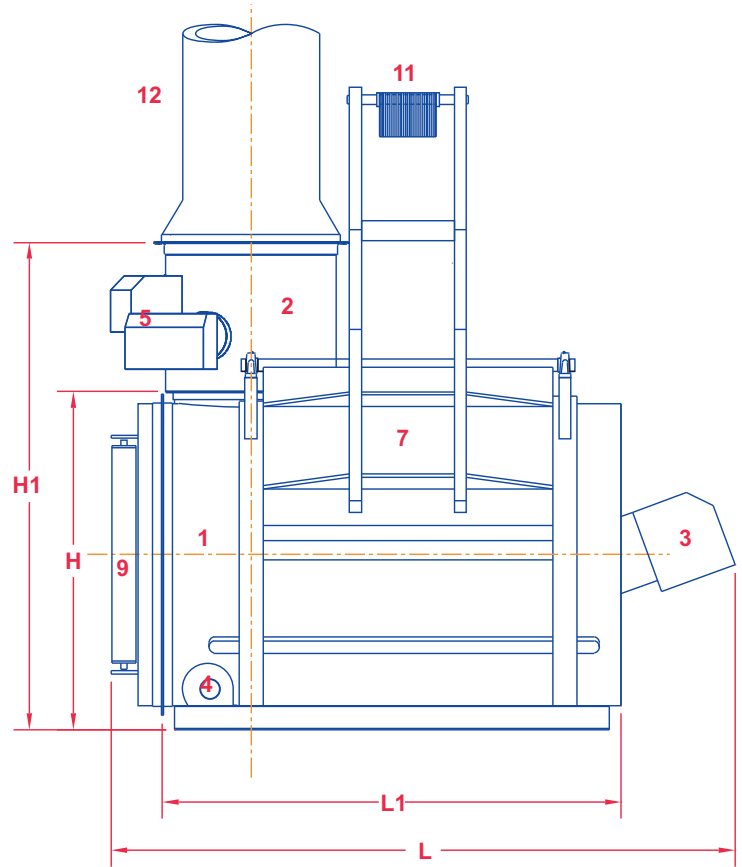
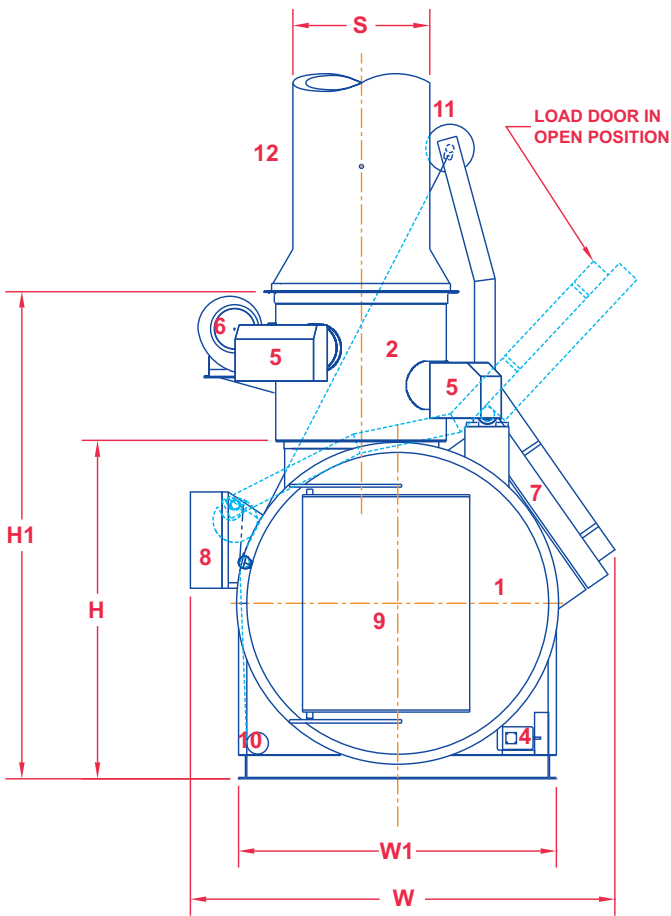

1. PRIMARY COMBUSTION CHAMBER
2. SECONDARY COMBUSTION CHAMBER
3. PRIMARY BURNER(S)

4. PRIMARY BLOWER
5. SECONDARY BURNER(S)
6. SECONDARY BLOWER

7. PRIMARY LOAD DOOR
8. CONTROL PANEL
9. CLEAN OUT DOOR

10. LOAD DOOR WINCH
11. LOAD DOOR COUNTERWEIGHT
12. INCINERATOR STACK

MODEL NUMBER	OVERALL DIMENSIONS ¹					LOAD DOOR OPENING L x W (FT)	MAX. CHARGE CU. FT.	BURN RATE (MAX.) LBS./HR. ²	APPROX. WEIGHT LBS. ³		
	H	H1	W	W1	L						
CA-50PAC	5'-10"	3'-9"	5'-3"	3'-2"	4'-8"	4'-0"	3'-4"	1'-6"x2'-0"	14	25	3,300
CA-100PAC	6'-4"	4'-5"	5'-11"	3'-10"	5'-8"	5'-0"	4'-3"	1'-6"x2'-0"	27	50	5,000
CA-150PAC	7'-4"	5'-3"	6'-9"	4'-8"	6'-4"	5'-6"	4'-5"	2'-0"x2'-6"	41	75	8,300
CA-200PAC	7'-7"	5'-3"	6'-9"	4'-8"	8'-4"	7'-6"	6'-4"	2'-0"x2'-6"	54	100	10,500
CA-300PAC	8'-7"	6'-5"	7'-7"	5'-8"	11'-7"	6'-10"	5'-4"	2'-6"x2'-6"	81	150	12,800
CA-400PAC	9'-0"	6'-5"	7'-7"	5'-8"	13'-9"	9'-0"	8'-0"	2'-6"x4'-6"	108	200	16,100
CA-500PAC	9'-8"	7'-0"	8'-2"	6'-3"	14'-3"	9'-6"	8'-0"	3'-0"x5'-0"	135	250	19,800

1. Dimensions can be modified to meet specific applications 2. Actual burning rate depends upon waste composition. 3. Weight will vary depending on the options ordered.

Services:

- Installation and start-up services
- Large parts inventory for immediate shipment
- Service and maintenance contracts for all makes
- Rebuilds and modifications to existing incinerators

Advanced Combustion Systems' Engineering and Testing Facilities are available for complete design and component selection. ACS can custom design and manufacture incineration and control systems to meet any specific application.

ACS, Inc. is your sole source manufacturer for complete incineration systems including waste handling, heat recovery, emission controls and monitoring.

ACS INCORPORATED

1999 ALPINE WAY BELLINGHAM, WA 98226

PHONE: 360.676.6005 FAX: 360.647.9439

TOLL FREE: 800.445.0243

WWW.ACS-ACS.COM



Made In America 734
20050707

